

SPRING HYDRANT VALVE

Version 2.0

Clover Spring Hydrant Valves are suitable for use in pressure water supply applications.

SPECIFICATIONS

Diameter Range: DN80 – DN100

Nominal Pressure: 1,600kPa

End Connections: AS/NZS4087 Fig. B5

Maximum Operating Temperature: 40°

Product Certification:

Australian Certification Services - 22026

Compliance:

- AS3952 "Water supply - Spring hydrant valve for waterworks purposes"
- AS/NZS4158 "Thermal-bonded polymeric coatings on valves and fittings for water industry purposes"
- AS1646 "Elastomeric seals for waterworks purposes"
- AS1831 "Ductile cast iron"
- AS/NZS4087 "Metallic flanges for waterworks purposes"
- AS/NZS4020 "Testing of products for use in contact with drinking water"

WSAA Product Appraisal: PA11/28

WSAA Purchase Specification:

- WSA PS267 – Hydrants (Spring) for Pressure Applications – Water Supply

Options & Accessories:

- Lilac coloured yoke for non-potable water applications
- Hydrant/Air isolation valve
- Hydrant covers
- Hydrant marker posts
- Flange gasket kits

Recommended Specifications:

- Spring hydrant valves shall be Clover type conforming to AS3952
- Spring hydrant valve allowable operating pressure shall be 1,600kPa
- Protective coatings of spring hydrant valves shall be thermally applied polymeric type in accordance with AS/NZS4158
- Flanges shall be raised face type in accordance with AS/NZS4087 Fig. B5



FEATURES

- 10 year manufacturers warranty
- Factory tested
- Reduced weight design
- Ductile iron body and yoke
- Local inventory available
- Manufactured & certified to AS3952
- Thermally bonded polymeric coating
- High strength and impact resistant ductile iron body and yoke
- Thermally bonded polymeric coating for long life corrosion protection
- Light weight environmentally friendly design for safe and simple installation
- Hydrostatically factory tested to guarantee field performance

APPLICATIONS

- Used to access pipelines via standpipe attachments for fire, flushing and scouring purposes.
- Potable and non-potable water supply
- Irrigation and raw water
- Fire systems
- Buried and above ground

SPRING HYDRANT VALVE

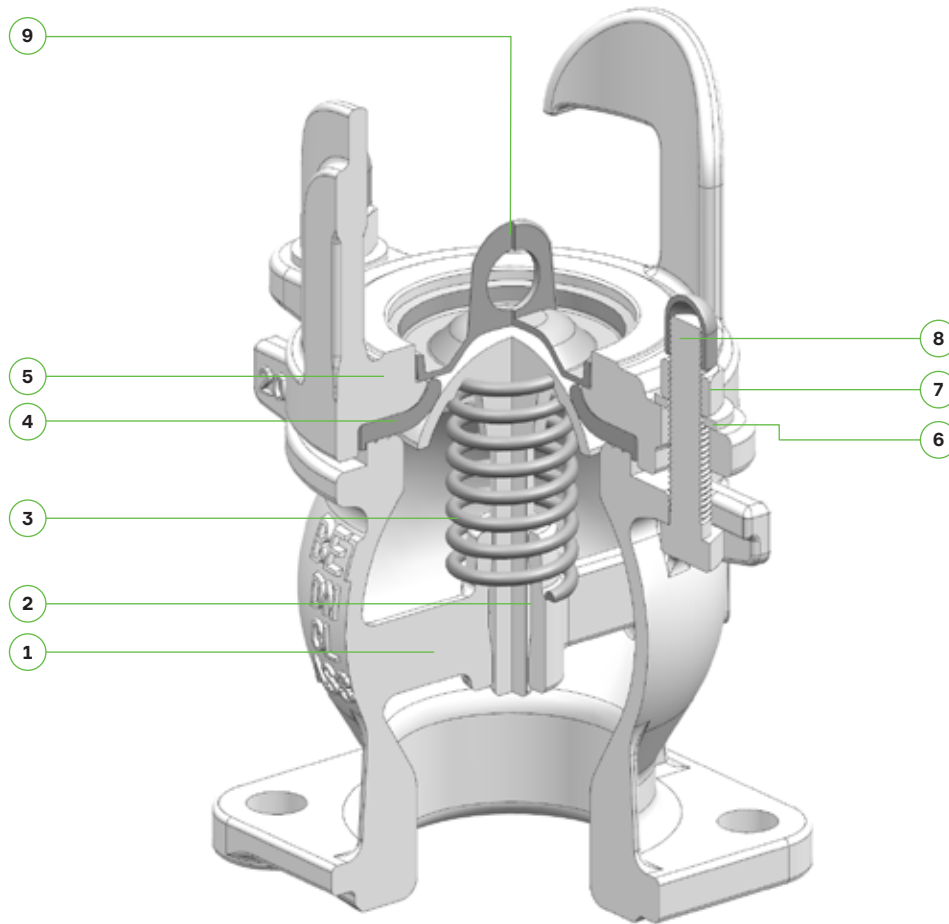

COMPONENTS

ITEM	PART NAME	MATERIAL	STANDARD/GRADE
1	Body	Ductile Iron/Polymeric Coating	AS1831 500-7/AS4158
2	Dome	Aluminium Bronze	C48600
3	Spring	304 Stainless Steel	ASTM 276/304
4	Seat Gasket	EPDM Elastomer	AS1646/EPDM
5	Yoke	Ductile Iron/Polymeric Coating	AS1831 500-7/AS4158
6	Washer	316 Stainless Steel	ASTM 276/316
7	Hex Nut	316 Stainless Steel	ASTM 276/316
8	Bolt	316 Stainless Steel	ASTM 276/316
9	Dust Cover	PVC	

SPRING HYDRANT VALVE

SPECIFICATIONS	SYM	UNITS	DN80	DN100
HEIGHT (CENTRE TO KEYCAP)	H	mm	264	264
WIDTH (FLANGE FACE)	W	mm	143	166
WIDTH (BOLT LUGS)	W1	mm	216	216
FLANGE BOLT HOLES	N	mm	4Ø18	4Ø18
PITCH CIRCLE DIAMETER	PCD	mm	146	178
WEIGHT OF UNIT (KEYCAP FITTED)		kg	11	13
PRODUCT CODE - POTABLE			VH080	VH100
PRODUCT CODE - NON-POTABLE (LILAC YOKE)			VH080L	VH100L

PRESSURE	SYM	UNITS	
PRESSURE NOMINAL	PN	Nom	16
ALLOWABLE OPERATING PRESSURE	AOP	kPa	1,600
MAXIMUM ALLOWABLE OPERATING PRESSURE	MAOP	kPa	1,920
ALLOWABLE SITE TEST PRESSURE	ASTP	kPa	2,000
PRODUCTION TEST - BODY		kPa	2,400
PRODUCTION TEST - SEAT		kPa	1,760

All dimensions are in millimetres.

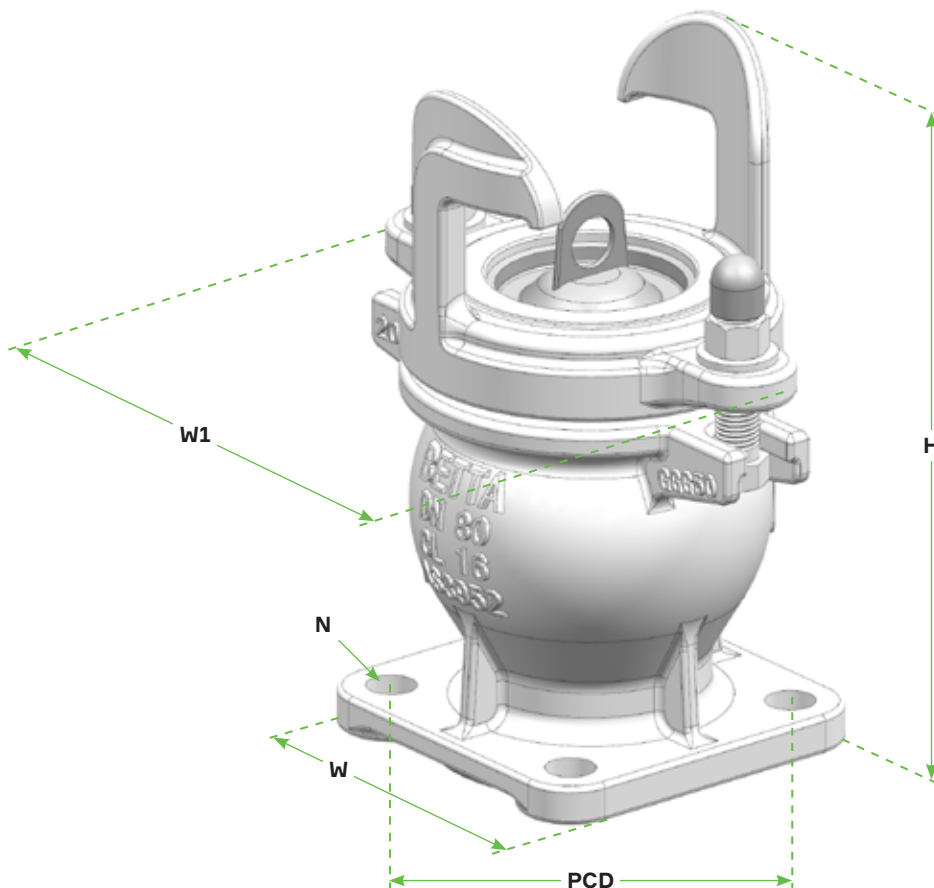

The products shown form part of our continuous improvement program and as such the product designs, specifications and materials may be changed without notice. All warranties relating to accuracy, completeness, or suitability for any particular purpose and all liability for any loss, damage or costs incurred relating to the use of this information are excluded.